

FLAIL MOWER FR 92 - 162

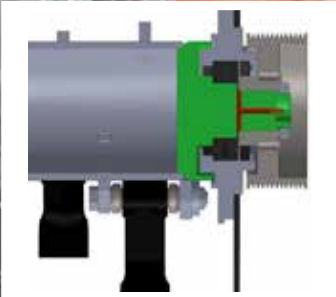

NEWS



OPTIMIZED TOTAL WIDTH

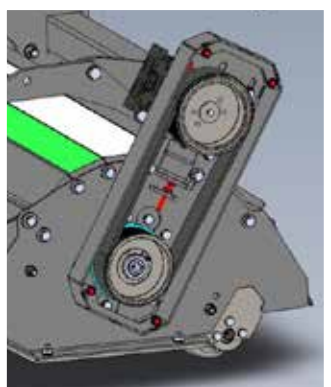

POWER BELT DRIVE

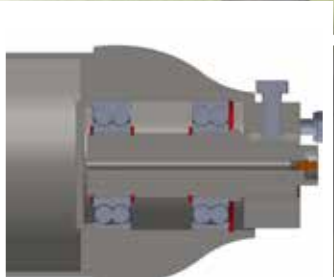

REAR ROLLER



OPTIMIZED SHAPE OF FLAILS

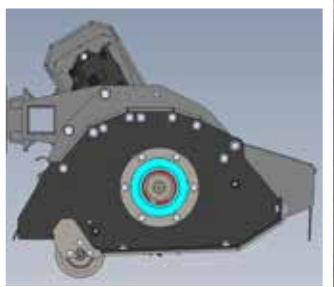

INTEGRATED AIRFLOW

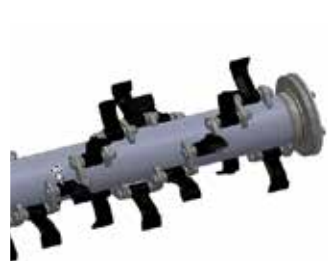

DOUBLE SPIRAL ROTOR





- m
0.9-1.6
- cm
< 4
- km/h
5-7
- kg
138-360

2
years
WARRANTY



STRONG ARGUMENTS

- **Integrated Airflow increases the capacity**
- **Integrated rotor bearings**
- **Power Belt drive**
- **Strenx 700 steel construction**
- **Double spiral rotor with uniform flow**

The Integrated Airflow system is one of the main features of the new FR series. The space between the rotor and the shield is purposely designed to increase the air velocity so the cut-off material exits the mower as quickly as possible. It creates a natural vacuum that sucks the grass into the mower. This increases the capacity of the flail head and reduces the power requirement. The main bearings are integrated in the rotor shaft which reduces the total width of the flail head. The flails are adapted to the rotor to stop breakage and damage from happening. The machines are manufactured in Strenx 700 high strength steel which is one of the most durable steel types in the world.

FLAIL MOWER FR	92	112	122	162
Working width (m)	0.9	1.1	1.2	1.6
Weight (kg)	138	144	320	360
Oil flow (l/min.)	40	40	85	85
Alt. oil flow (l/min.)	50	50	100	100